

**TECHNICAL GUIDE  
&  
PARTS CATALOGUE**

**Cal.NH3 Series**

**AUTOMATIC MECHANICAL**

**SII Products**

Movement											
Movement size	Outside diameter	Φ27.40mm									
	Casing diameter	Φ29.36mm (with dial holding spacer)									
	Total height	5.32mm									
Cal. No.		NH35		NH36		NH37		NH38		NH39	
Time indication	3Hands (hour, minute, second)	○		○		○		○		○	
	Date calendar	○		○		○		-		-	
	Day calendar	-		○		-		-		-	
	24hour indicator	-		-		○		-		○	
Basic function	Manual winding	○		○		○		○		○	
	Automatic winding with ball bearing	○		○		○		○		○	
	Time setting with stop-second device	○		○		○		○		○	
	Date display with quick change	○		○		○		-		-	
	Day display with quick change	-		○		-		-		-	
Frequency		21,600 vibrations per hour									
Accuracy	Static accuracy	-25~+35 seconds per day * Measurement should be done within 10~60 minutes after fully wound up. * All measurements are made without the calendar in function.									
	Measurement position	Direction of 3 positions. (1) Dial up (2) 9 o'clock up (3) 6 o'clock up									
	Lift angle	53 deg.									
	Measurement time	20 seconds * Equipment to be used : Witschi WATCH EXPERT									
	Posture difference	Difference is under 60 seconds within max value and minimum value * Measurement should be done within 10~60 minutes after fully wound up. * Direction of 4 positions. (1) 12 o'clock up (2) 9 o'clock up (3) 6 o'clock up (4) 3 o'clock up									
	Isochronisms (24h-0h)	-20~+40 seconds per day. * Measurement position : Dial up * Difference of static accuracy of 24h and 0h									
Duration time		More than 41 hours ... Mainspring after fully wound up. * Posture to confirmation : Dial up									
Winding the mainspring		<< Movement >> • Fully wound up by turning the crown minimum 55 times. • Fully wound up by turning the ratchet wheel screw 8 times. << Complete Watch >> A winding machine is needed to wind up the mainspring. Full wind up conditions • Rotary speed : 30 rpm • Operating time: 60 minutes									
Jewels		24 jewels									
Crown position	Normal position	Left rotation	Free								
		Right rotation	Manual winding								
	First click	Left rotation	Date setting	Date setting	Date setting	Time setting with stop-second device					
		Right rotation	Free	Day setting	Free						
Second click		Time setting with stop-second device									-

Disassembling procedures Figs.

NH35/37 ④ → ⑱ NH36 ① → ⑱

Reassembling procedures Figs.

NH35/37 ⑱ → ④ NH36 ⑱ → ①

Type of oil

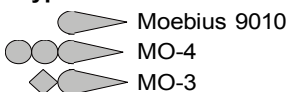

Oil quantity mark

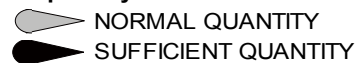

<<NH35/36/37>>

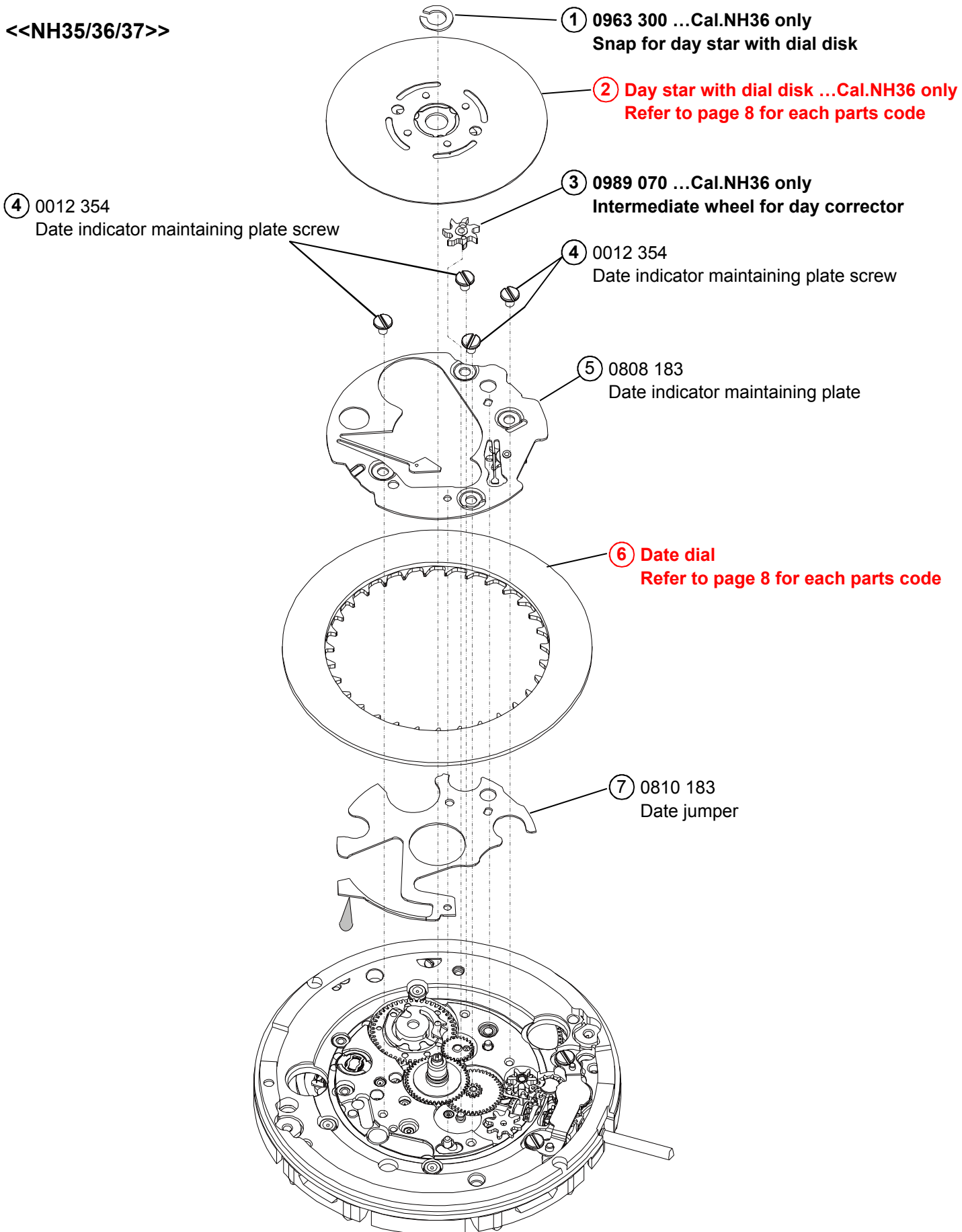

**Type of oil**

Moebius 9010

MO-4  
MO-3

**Oil quantity mark**

NORMAL QUANTITY  
SUFFICIENT QUANTITY

<<NH35/36/37>>

**14 Hour wheel**  
Refer to page 9 for each parts code

**15 0261 183**  
Minute wheel and pinion

**16 Refer to page 9 for each parts code**

**17 Refer to page 9 for each parts code**

**18 Cannon pinion**  
Refer to page 8 for each parts code

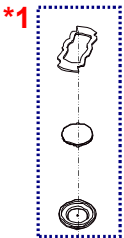
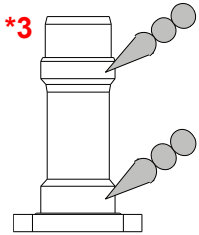

- \*1** **37-1** Lower shock absorbing spring
- 37-2** Lower shock absorbing cap jewel
- 37-3** Lower hole jewel frame for shock-absorber

**8 0962 025**  
Day-date corrector setting transmission wheel E

**9 0012 485**  
Guard for day-date corrector setting transmission wheel screw

**10 0836 183**  
Guard for day-date corrector setting transmission wheel





**11 0962 185**  
Day-date corrector setting transmission wheel C

**12 0962 023**  
Day-date corrector setting transmission wheel B

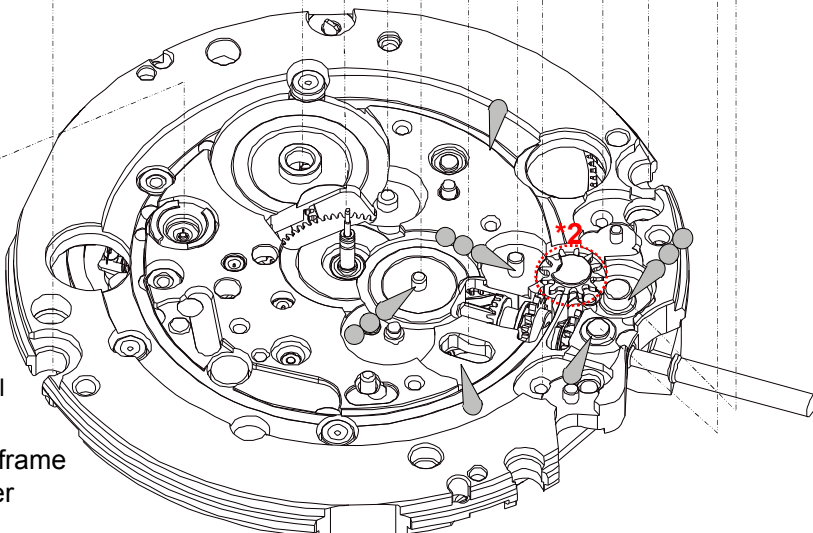
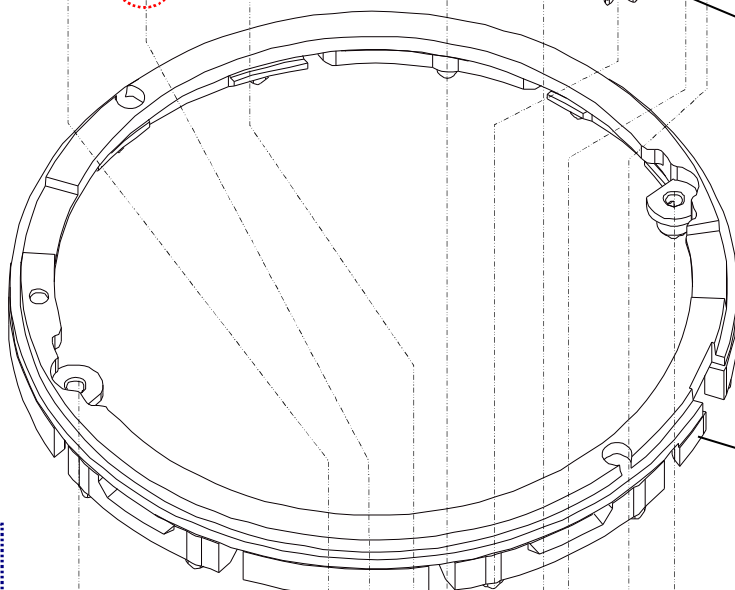
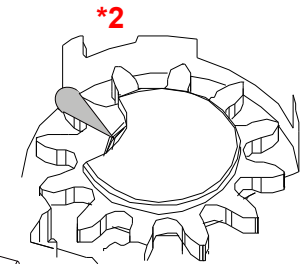
**13 0737 183**  
Day-date corrector wheel

**19 4408 172**  
Dial holding spacer



<p>Disassembling procedures Figs. NH38/39 ① → ⑧ Reassembling procedures Figs. NH38/39 ⑧ → ①</p>	<p><b>Type of oil</b></p> <ul style="list-style-type: none"> <li> Moebius 9010</li> <li> MO-4</li> <li> MO-3</li> </ul>	<p><b>Oil quantity mark</b></p> <ul style="list-style-type: none"> <li> NORMAL QUANTITY</li> <li> SUFFICIENT QUANTITY</li> </ul>
---	--	--

<<NH38/39>>

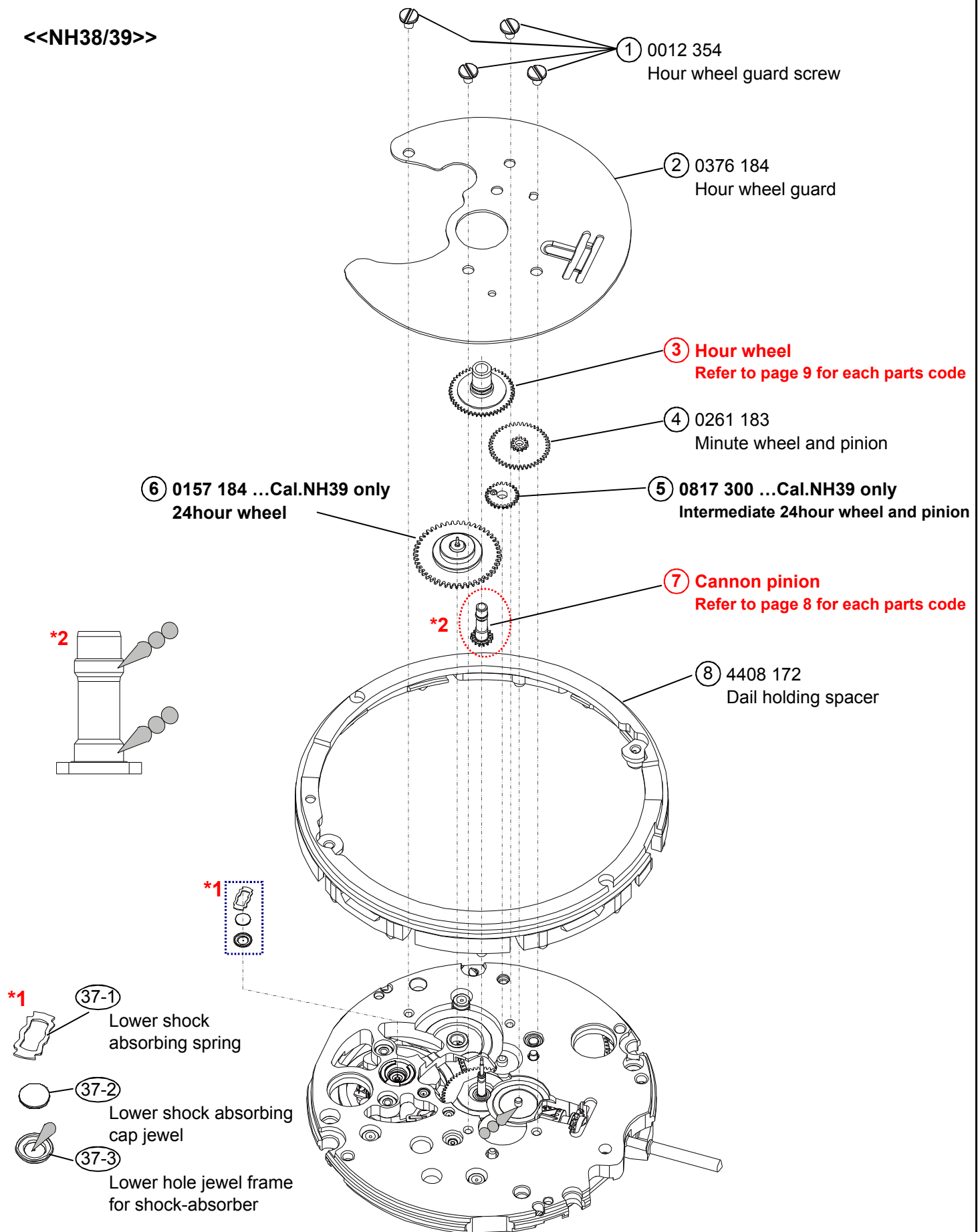

① 0012 354  
Hour wheel guard screw

② 0376 184  
Hour wheel guard

③ **Hour wheel**  
Refer to page 9 for each parts code

④ 0261 183  
Minute wheel and pinion

⑥ 0157 184 ...Cal.NH39 only  
24hour wheel

⑤ 0817 300 ...Cal.NH39 only  
Intermediate 24hour wheel and pinion

⑦ **Cannon pinion**  
Refer to page 8 for each parts code

⑧ 4408 172  
Dial holding spacer

\*1

③7-1 Lower shock absorbing spring

③7-2 Lower shock absorbing cap jewel

③7-3 Lower hole jewel frame for shock-absorber

<p>Disassembling procedures Figs. ① → ③⑦</p> <p>Reassembling procedures Figs. ③⑦ → ①</p>	<p><b>Type of oil</b></p> <p>● Moebius 9010</p> <p>● MO-4</p> <p>◆ MO-3</p>	<p><b>Oil quantity mark</b></p> <p>◐ NORMAL QUANTITY</p> <p>◑ SUFFICIENT QUANTITY</p>
--	---	---

**① Oscillating weight with ball bearing**  
Refer to page 8 for each parts code

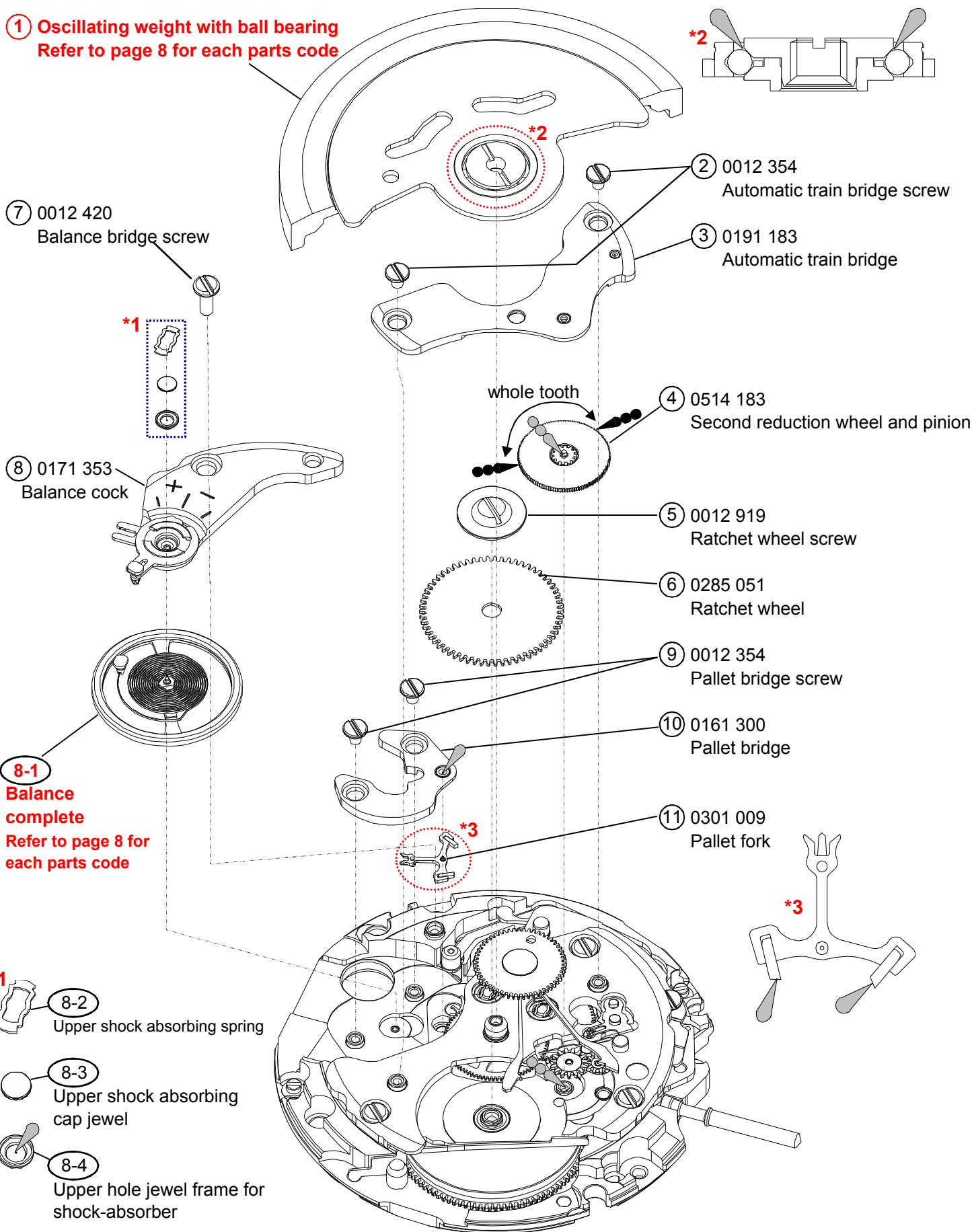

⑦ 0012 420  
Balance bridge screw

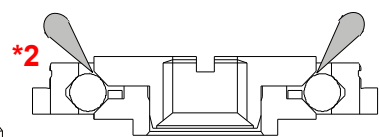

② 0012 354  
Automatic train bridge screw

③ 0191 183  
Automatic train bridge

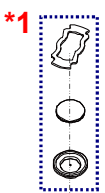

⑧ 0171 353  
Balance cock

whole tooth

④ 0514 183  
Second reduction wheel and pinion

⑤ 0012 919  
Ratchet wheel screw

⑥ 0285 051  
Ratchet wheel

⑨ 0012 354  
Pallet bridge screw

⑩ 0161 300  
Pallet bridge

**8-1**  
**Balance complete**  
Refer to page 8 for each parts code

⑪ 0301 009  
Pallet fork

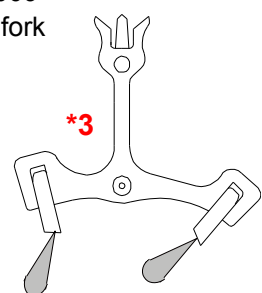





\*1

⑧-2  
Upper shock absorbing spring

⑧-3  
Upper shock absorbing cap jewel

⑧-4  
Upper hole jewel frame for shock-absorber

Type of oil		Oil quantity mark	
	Moebius 9010		NORMAL QUANTITY
	MO-4		SUFFICIENT QUANTITY
	MO-3		

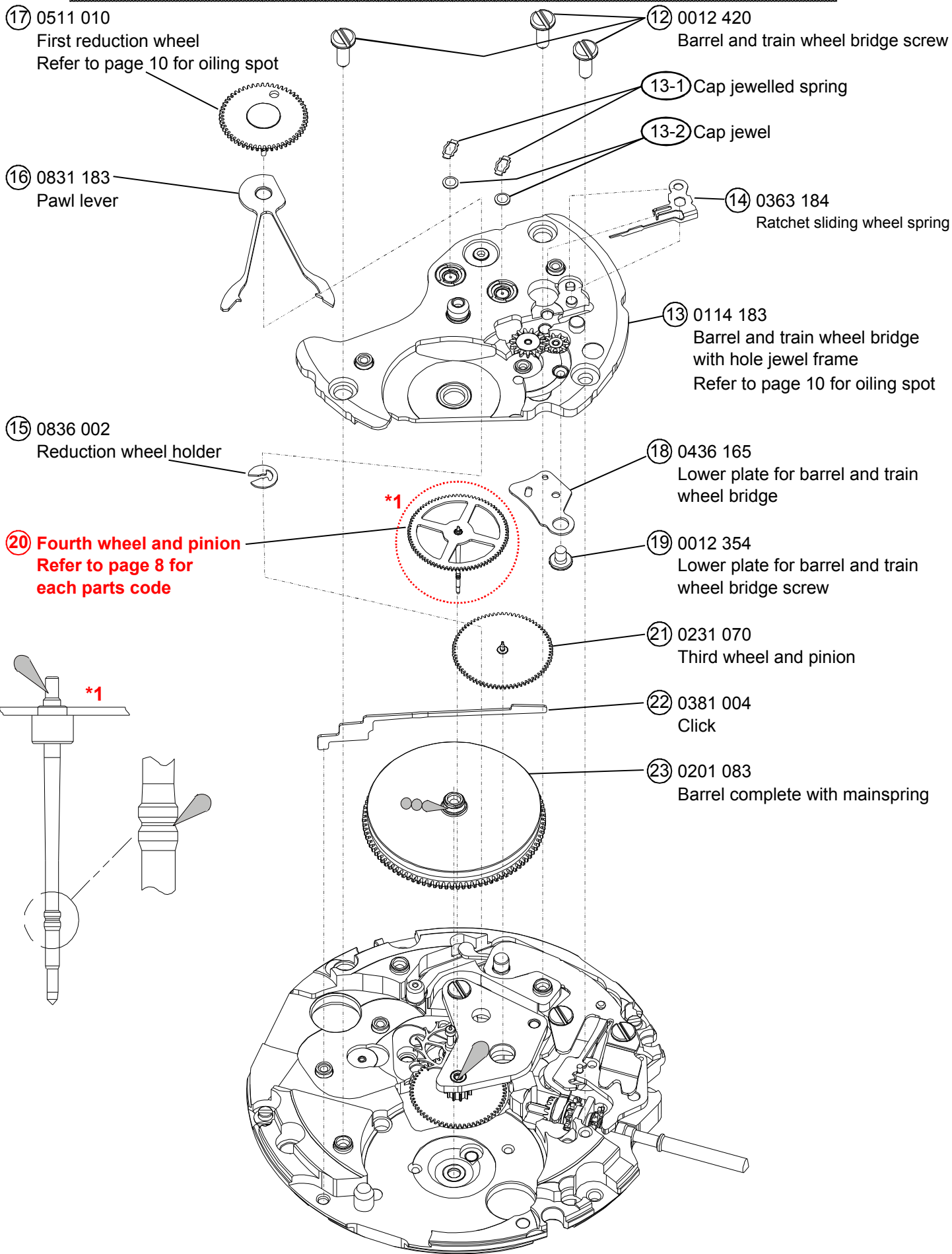



**Type of oil**

Moebius 9010

MO-4  
MO-3

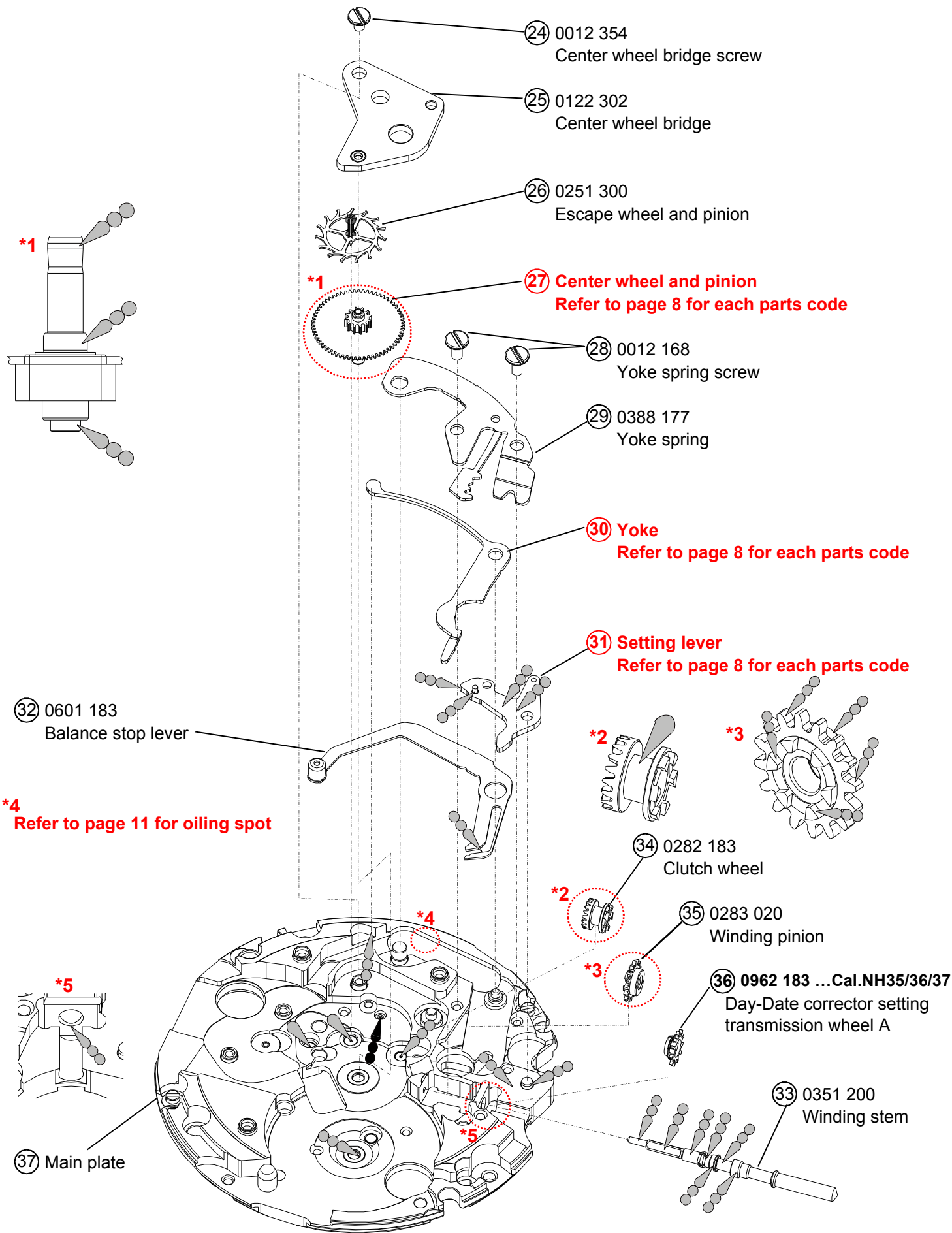

**Oil quantity mark**

NORMAL QUANTITY  
SUFFICIENT QUANTITY



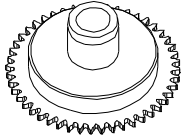
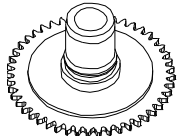
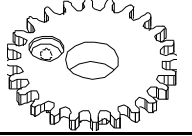
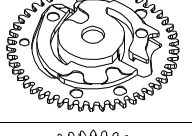

Remarks: Different parts for each CAL.

Page	No	Cal.					Parts code	Parts name	Parts form
		NH35	NH36	NH37	NH38	NH39			
P-3	⑭	O	-	-	-	-	0273 182	Hour wheel 0273 182 ⇒ 0273 184 (Height difference)	
		-	O	-	-	-	0273 183		
		-	-	O	-	-	0273 184		
P-4	⑬	-	-	-	O	-	0273 183	0273 183 ⇒ 0273 185 (Height difference)	
		-	-	-	-	O	0273 185		
P-3	⑯	O	O	-	-	-	0817 300	Intermediate date driving wheel and pinion	
		-	-	O	-	O		Intermediate 24hour wheel and pinion	
P-3	⑰	O	O	-	-	-	0802 183	Date indicator driving wheel	
		-	-	O	-	-	0157 182	24hour wheel	

■ List of screw

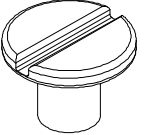
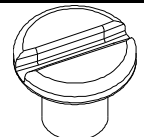
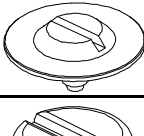
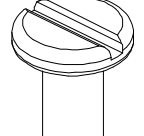
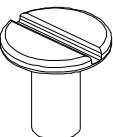
Page	No	Parts code	Parts name	Parts form	Page	No	Parts code	Parts name	Parts form
P-2	④	0012 354	Date indicator maintaining plate screw (x4)		P-3	⑨	0012 485	Guard for day-date corrector setting transmission wheel screw (x2)	
P-4	①		Hour wheel guard screw (x4)		P-5	⑤	0012 919	Ratchet wheel screw	
P-5	②		Automatic train bridge screw (x2)		P-5	⑦	0012 420	Balance bridge screw	
	⑨		Pallet bridge screw (x2)					P-6	
P-6	⑰		Lower plate for barrel and train wheel bridge screw		P-7	⑳	0012 168	Yoke spring screw (x2)	
P-7	⑳		Center wheel bridge screw						

**② Day star with dial disk ... Cal.NH36 only (P-2)**

Parts code	Position of crown	Position of day frame	Color of letters	Color of background	Language
0160 242	3H	3H	MON~FRI : Black SAT : Blue SUN : Red	White	English & Spanish

**⑥ Date dial ... Cal.NH35 / NH36 / NH37 (P-2)**

Cal.	Parts code	Position of crown	Position of day frame	Color of letters	Color of background
NH35 NH37	0878 208	3H	3H	Black	White
NH36	0878 206	3H	3H	Black	White

**⑱ Cannon pinion ...NH35/36/37 (P-3)**

Cal.	Parts code	Cal.	Parts code
NH35 NH36	0225 416	NH37	0225 417

**⑦ Cannon pinion ...NH38/39 (P-4)**

Cal.	Parts code	Cal.	Parts code
NH38	0225 416	NH39	0225 417

**① Oscillating weight with ball bearing (P-5)**

Cal.	Parts code	Marking	Cal.	Parts code	Marking	Cal.	Parts code	Marking
NH35	0509 467	Japan mark	NH36	0509 463	Japan mark	NH37	0509 470	Japan mark
	0509 468	Malaysia mark		0509 464	Malaysia mark		0509 471	Malaysia mark
NH38	0509 476	Japan mark	NH39	0509 473	Japan mark			
	0509 477	Malaysia mark		0509 474	Malaysia mark			

**⑧-1 Balance complete with stud (P-5)**

Cal.	Parts code	Cal.	Parts code
NH35 NH36 NH37	0310 197	NH38 NH39	0310 198

**⑩ Fourth wheel and pinion (P-6)**

Cal.	Parts code	Cal.	Parts code
NH35 NH36 NH38	0144 184	NH37 NH39	0144 185

**⑳ Center wheel and pinion with cannon pinion (P-7)**





Cal.	Parts code	Cal.	Parts code
NH35 NH36 NH38	0224 184	NH37 NH39	0224 185

**⑳ Yoke (P-7)**

Cal.	Parts code	Cal.	Parts code
NH35 NH36 NH37	0384 183	NH38 NH39	0384 184

**㉑ Setting lever (P-7)**

Cal.	Parts code	Cal.	Parts code
NH35 NH36 NH37	0383 183	NH38 NH39	0383 184

Type of oil	Oil quantity mark
 Moebius 9010	 NORMAL QUANTITY
 MO-4	 SUFFICIENT QUANTITY
 MO-3	

**1.Oiling spot**

**(13) Barrel and train wheel bridge with hole jewel frame**

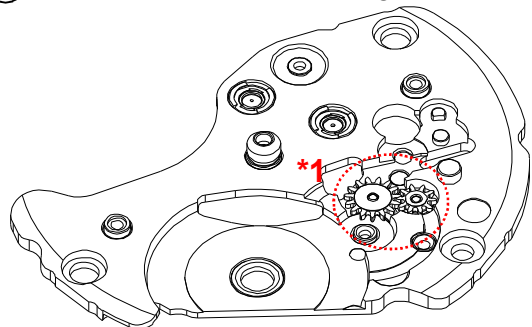

\*1

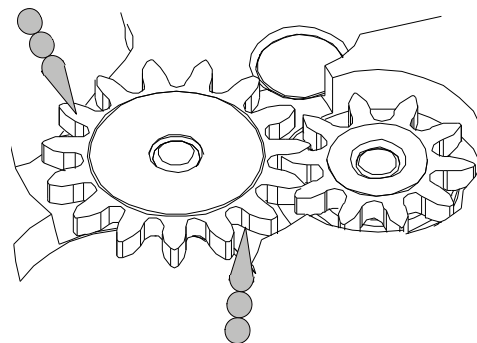

Barrel and train wheel bridge with hole jewel frame (back side)

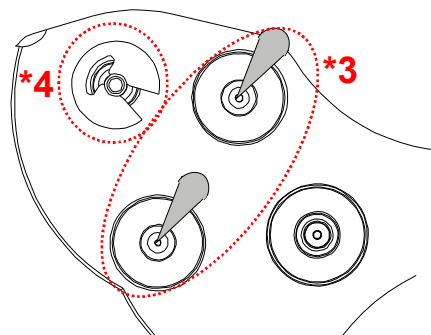
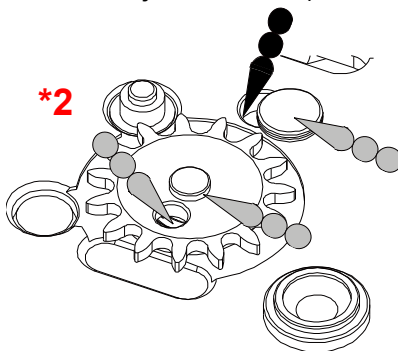
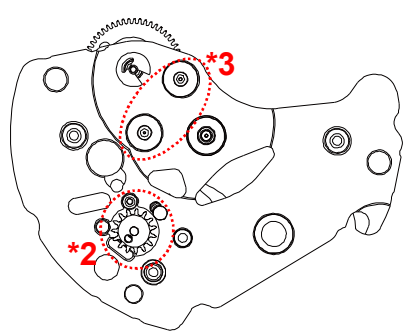

**Note**

**\*2 After oiling, set lower plate for barrel and train wheel bridge & screw.**

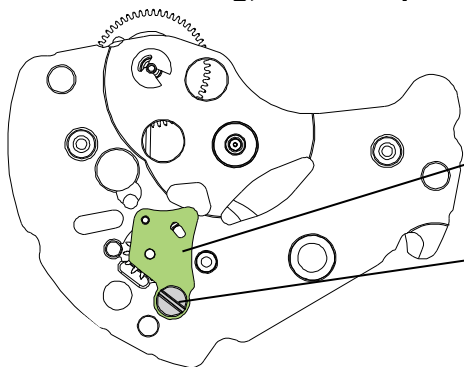

(18) Lower plate for barrel and train wheel bridge

(19) Lower plate for barrel and train wheel bridge screw

**\*4 After oiling, set first reduction wheel & pawl lever & reduction wheel holder.**

**(17) First reduction wheel**

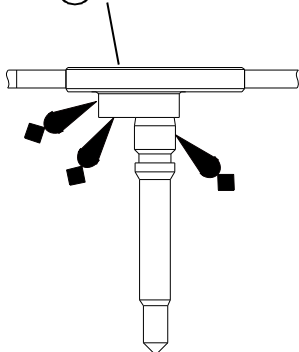

(17) First reduction wheel

(16) Pawl lever

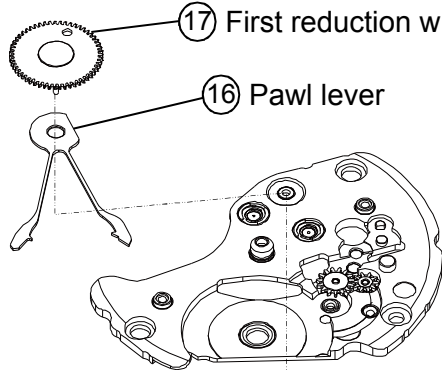

(15) Reduction wheel holder

③② Balance stop lever

Balance stop lever

Main plate

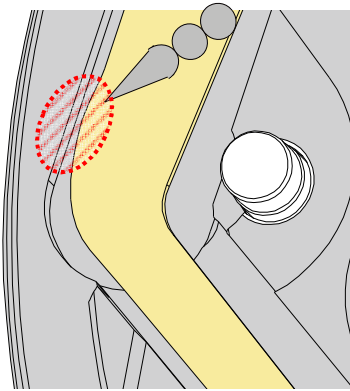
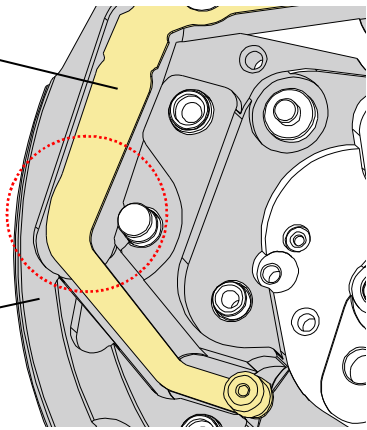

**Contact part of main plate and balance stop lever**

**2. Setting position of oscillating weight**

• Before assembling oscillating weight.

Match the center of the oscillating weight and winding stem. Set the hole of first reduction wheel gear on the imaginary line toward the balance bridge guide pin.

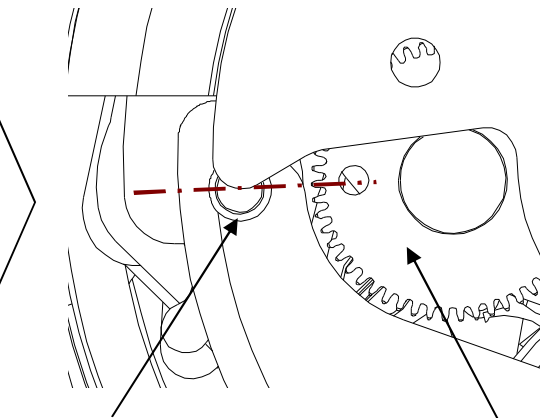
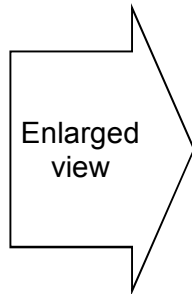
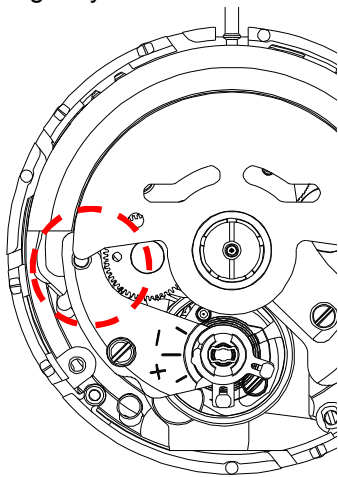

Balance bridge guide pin

First reduction wheel gear

**3. To remove the winding stem**

- 1) Set the winding stem to normal position.
- 2) Pull out the winding stem, while pushing "A"

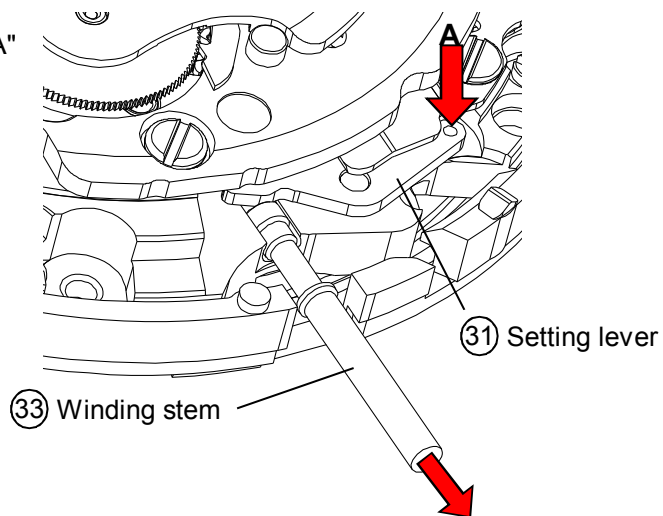

③① Setting lever

③③ Winding stem

**4. Disassembling / assembling of the First reduction wheel**

<< Disassembling >>

<< Assembling >>

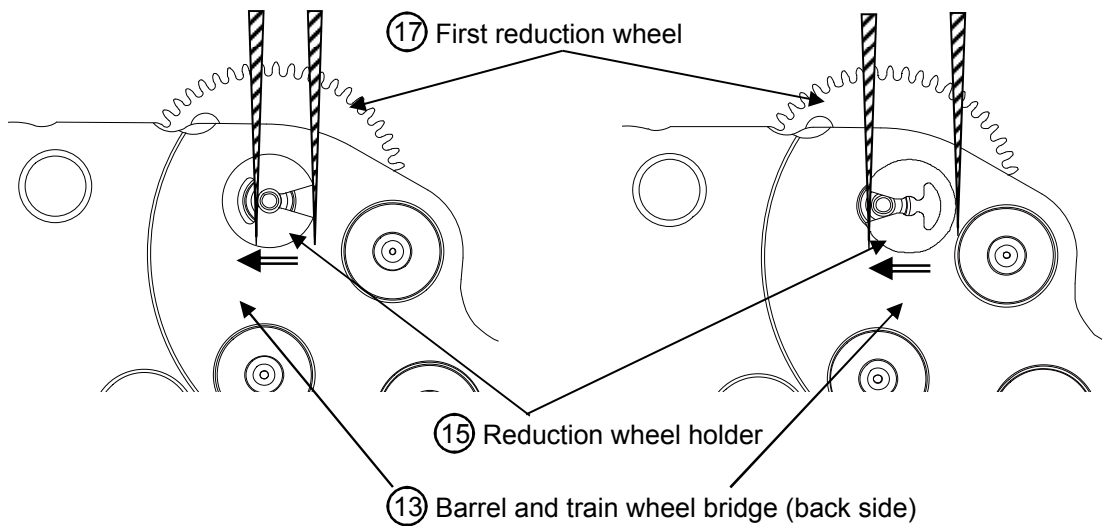

**5. Disassembling / assembling of the Ratchet sliding wheel spring.**

<< Disassembling >>

<< Assembling >>

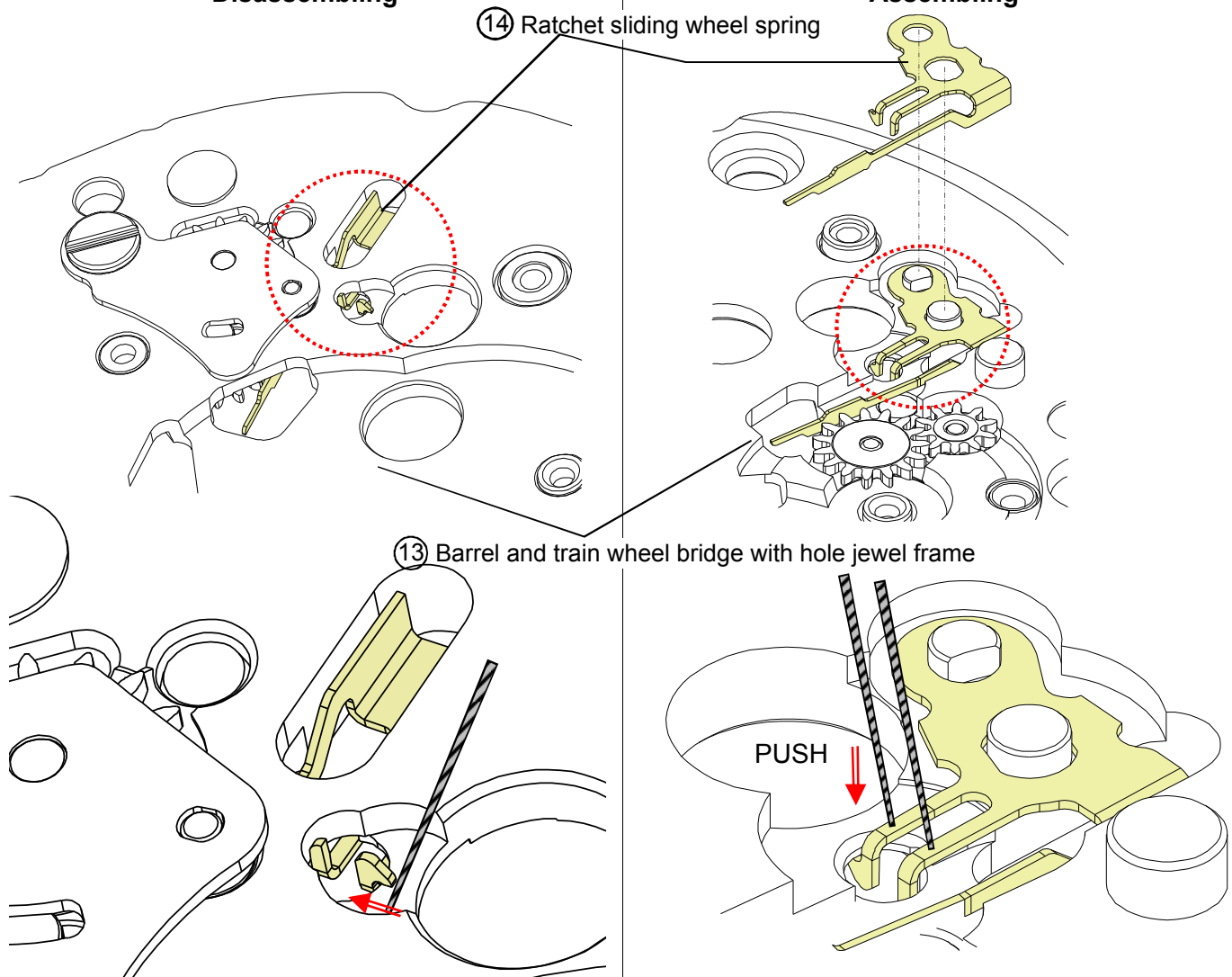

Remove the hook of the ratchet sliding wheel spring from barrel and train wheel bridge with hole jewel frame.

The hooks of ratchet sliding wheel spring are hung up on barrel and train wheel bridge with hole jewel frame.

**6.Accuracy adjustment**

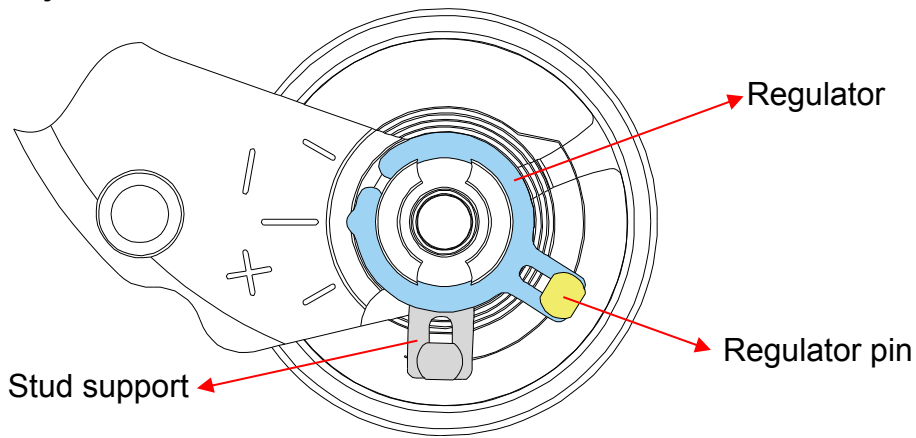

**Note:**

•Regulator ... Time adjustment

•Stud support ... Beat error adjustment

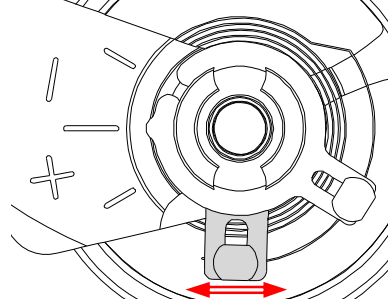
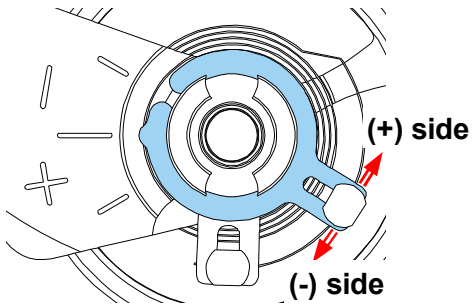

•Regulator pin ... Gap adjustment of balance spring and regulator pin

Anticlockwise rotation

No clockwise rotation

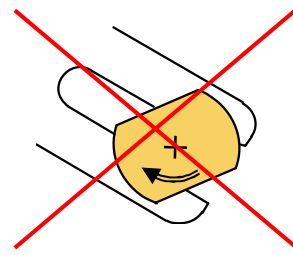
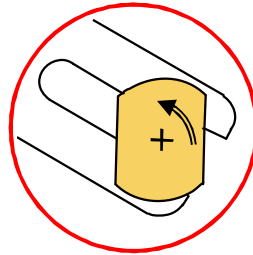
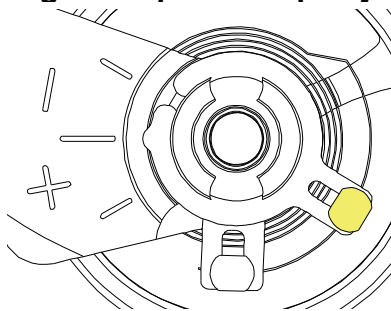



**7.To wind up the mainspring**

<<Movement>>

The mainspring would be fully wound up by turning the ratchet wheel screw 8 times clockwise. (Manual winding or Screwdriver)

Manual winding ... Rotate crown clockwise at normal position by min 55 times. (Equal to ratchet wheel screw 8 times )

Screwdriver winding ... Turn the ratchet wheel screw 8 times clockwise.

[ Manual winding ]

[ Screwdriver winding ]

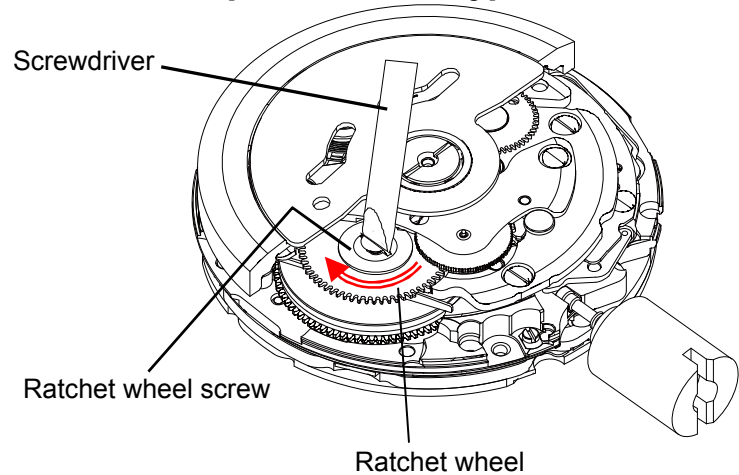
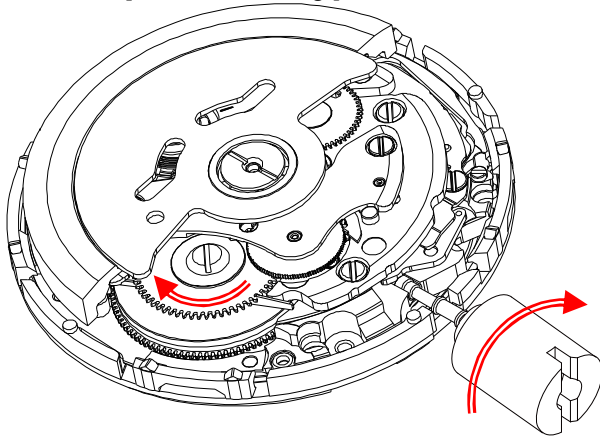

**8.How to attach hands**

Place the movement directly on a flat metal plate or something similar to attach the hands.

We recommend the use of movement holder to attach hands.

For hands attachment, please use a special equipment.

When the movement receives a strong shock, it may be damaged.

**\*Install the 24hour hand. ...Cal.NH37 & NH39**

Pull out the crown to the second click position and rotation it clockwise to install 24hour hand.

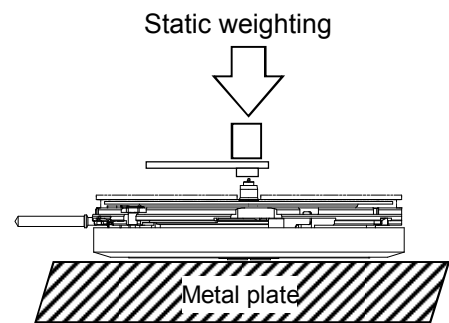

**9.Accuracy measurement condition**

Static Accuracy : -25~+35 seconds per day

Measurement Conditions

- 1) Measurement should be done within 10~60 minutes after fully wound up.
- 2) Lift angle : 53 deg
- 3) Measurement position : (1) Dial up (2) 9 o'clock up (3) 6 o'clock up
- 4) Minimum measurement Time : 20 seconds
- 5) Stabilizing Time :

Leave the watch for at least 20 seconds to stabilize after you change its measurement position.

**10.About the handling ...Cal.NH38 & 39**

○ Part is processed as a mirror surface. It is damaged when touching with tweezers.

Please be careful about the handling.

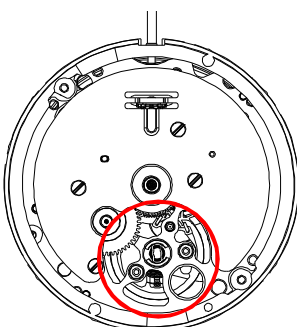

**NH35 / NH36 / NH37**

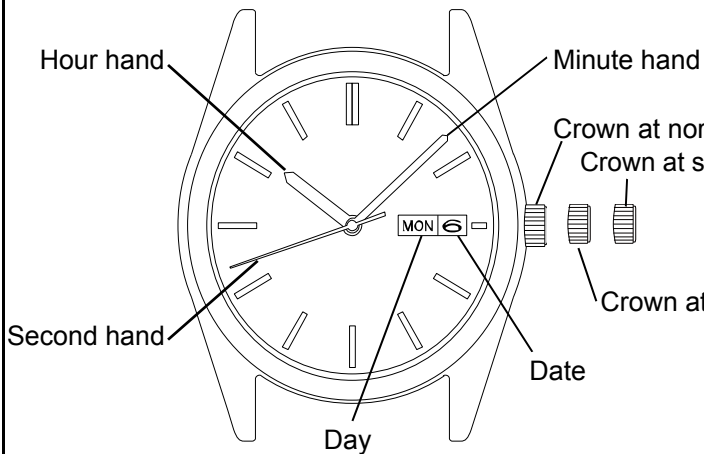

**NH38 / NH39**

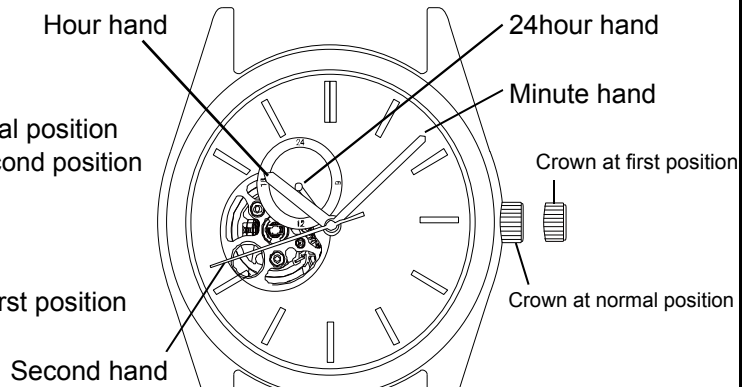

Time indication	NH35	NH36	NH37	NH38	NH39
3Hands (hour, minute, second)	○	○	○	○	○
Date calendar	○	○	○	-	-
Day calendar	-	○	-	-	-
24hour indicator	-	-	○	-	○

**1.How to set the time**

- 1) Pull out the crown to the second click position. ...Cal.NH35 & NH36 & NH37  
Pull out the crown to the first click position. ...Cal.NH38 & NH39
- 2) Turn the crown to set hour and minute hands.  
(Check that AM / PM is set correctly.)
- 3) Push the crown back into the normal position.

**2.How to set the Date ...Cal.NH35 & NH36 & NH37**

- 1) Pull out the crown to the first click position.
- 2) Turn the crown to left for date setting.
- 3) Turn the crown to right for day setting. ...Cal.NH36 only  
\*Do not set the date between 9:00 P.M. and 4:00 A.M. as this will cause a malfunction.
- 3) Push the crown back into the normal position.

**3.To wind up the mainspring**

- a) Manual winding ... Rotate the crown clockwise at normal position.  
Wind turning the ratchet wheel screw 8 times. It will start to move naturally after shaking slightly.
- b) To wind up with winding machine.  
Full wind up conditions
  - Rotary speed : 30 rpm
  - Operating time : 60 rpm